

Caution | Please Read the Manual Before Use.
Real Color of Product and Catalog Image Color Can Be Different.
Contents in This Catalog Can Be Changed Without Any Notice.



SCADA / PC SERIES



SCADA / PC SERIES

Product Catalog

MX On Corporation

HEAD ADDRESS: 11-35, Simin-daero 327beon-gil, Dongan-gu, Anyang-si, Gyeonggi-do 14055, Republic of Korea
OFFICE TEL: 82-31-465-3366
FAX: 82-31-465-3355

V 1.0E 251225

mxon.co.kr/eng

MX On Corporation Is an AX·DX-Based Smart Factory Total Solution Platform Company with Technical Expertise Extending from HMI/SCADA Development and Manufacturing to Robot Control and Logistics Automation.

SCADA / PC SERIES

CONTENTS

SCADA / PC Product Line-up Overview	04P	TOP-VIEW SERIES Industrial SCADA	10P	MPC SERIES Industrial Box PC	20P
Operation in Industrial Applications Industrial IoT Gateway	06P	TOP-WVIEW SERIES Industrial Web SCADA	12P	MDP SERIES Industrial Touch Monitor	26P
TOP Design Studio Software Overview	08P	TOP-PCVIEW SERIES Industrial Panel PC	14P	Global Business Network & Services Sales	30P

SCADA / PC LINE-UP

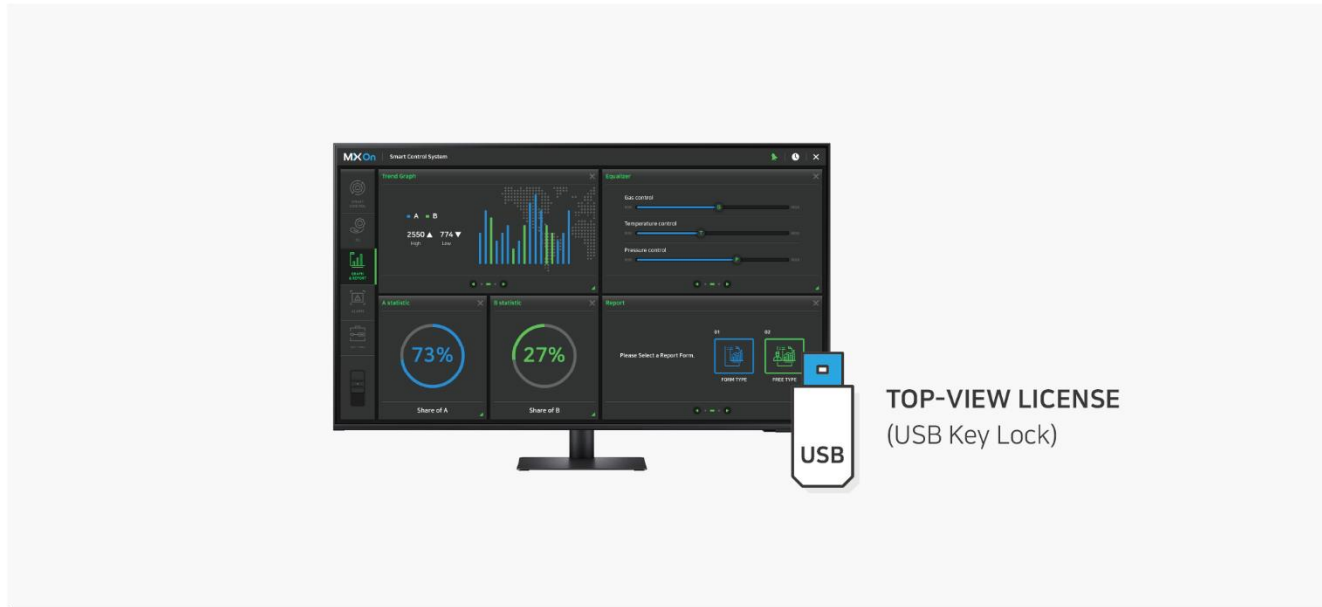

TOP-VIEW LICENSE
(USB Key Lock)

TOP-VIEW SCADA

100, 300, 600, 1300, 2000, Full Tags

Integrated Operation System for Real-Time Monitoring and Control of Industrial Equipment and Processes

Industrial SCADA

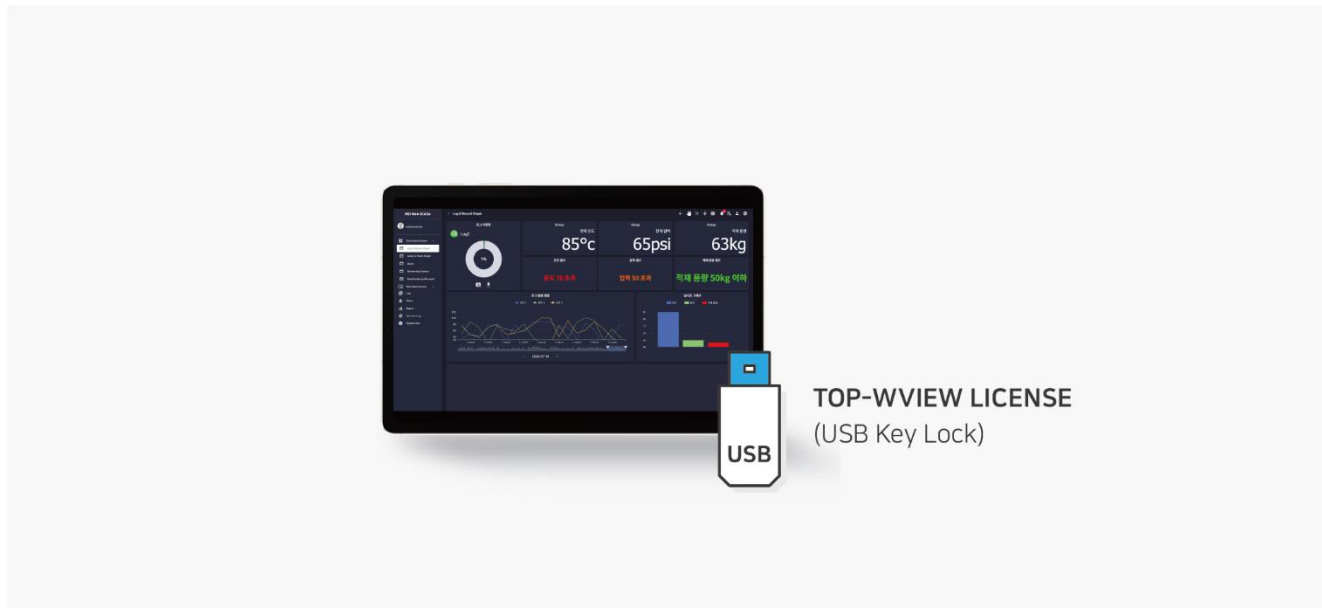

TOP-WVIEW LICENSE
(USB Key Lock)

TOP-WVIEW Web SCADA

Concurrent Users – Supports 2, 5, 10, or Unlimited

Web-Based SCADA for Real-Time Monitoring and Control via a Web Browser

Industrial Web SCADA



TOP-PCVIEW

19 17 15 12 10

Panel-Type PC with a Robust Aluminum Frame and Touch Interface for Stable Operation

Industrial Panel PC



MPC BOX PC

Box-Type PC with Efficient Heat Dissipation Structure and Robust Build

Industrial Box PC



MDP Touch Monitor

19

Touch Monitor with 1 or 2 Channel Support, FHD Display, and Capacitive Touch for Harsh Environments

Industrial Touch Monitor

HMI (TOP) / SCADA (TOP-VIEW) Operation in Industrial Sites

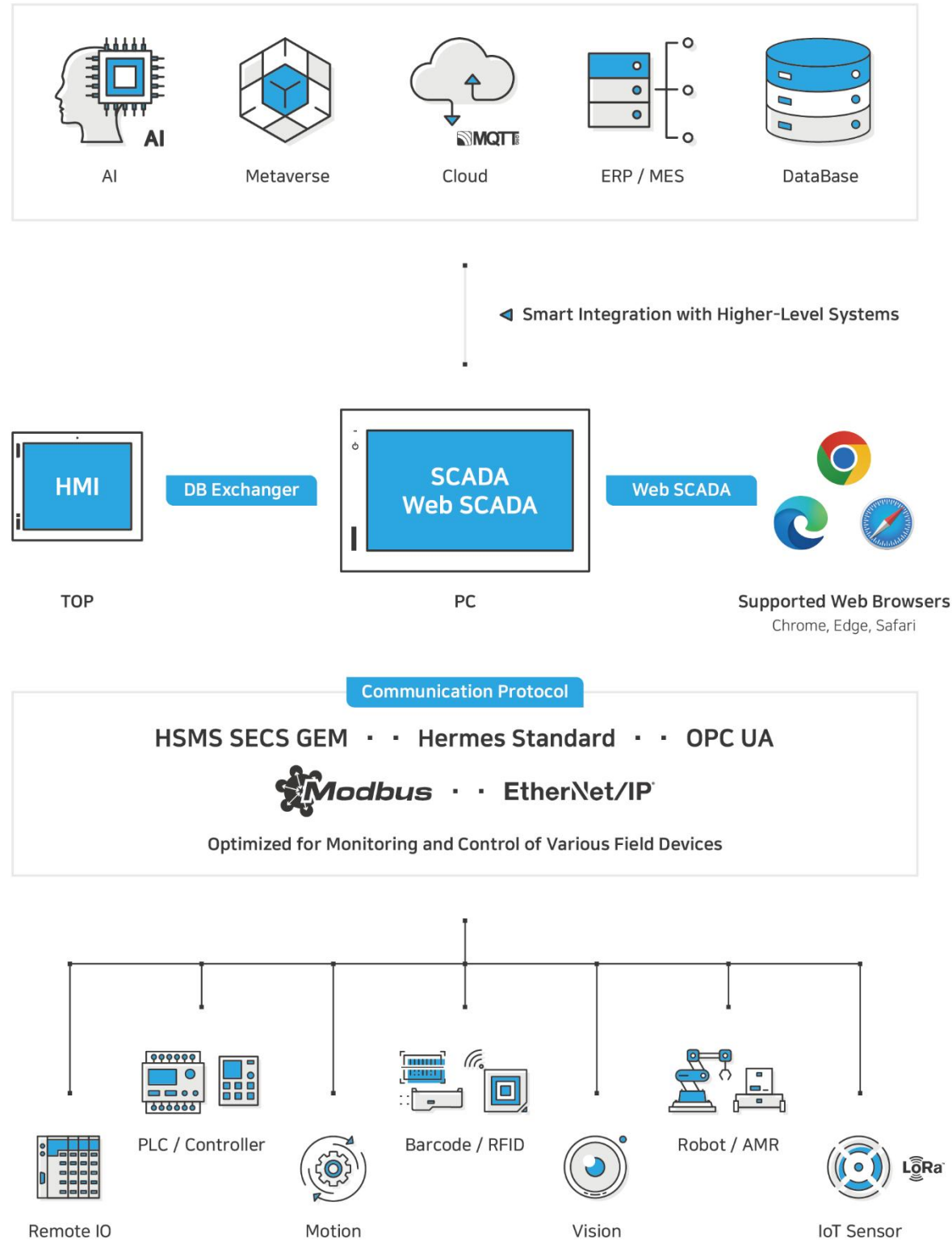

KEY FEATURES



Easily Integrate with Higher-Level Systems Using a Database

With an Intuitive UI, You Can Easily Link, View, and Edit Database Entries. HMI Data Can Also Be Stored in the Database via the DB Exchanger Function and Accessed from SCADA.



Provide Various Types of Reports According to User Requirements

Users Can Create or Print Reports in Various Formats Using Excel. Various Templates Used On-Site Can Also Be Applied, and Reports Can Be Printed Directly via a Printer Without Opening Excel.

21 CFR Part 11

Provides 21 CFR Part 11 Security

Complies with the U.S. FDA 21 CFR Part 11 Standard, Enabling Worker Authentication, Audit Trail Tracking, Database Management, and PDF Handling for a Safe and Efficient Working Environment.

VNC

Proprietary VNC Provided

With Our High-Performance Proprietary VNC, You Can Remotely Access TOP & TOP-VIEW Screens in Industrial Sites and Monitor or Control Them in Real Time via Mobile, Tablet, or PC.

OPC UA

Supports Industrial-Standard OPC UA

The Forward-Looking and Highly Extensible OPC UA Protocol Enables Reliable Data Collection and Management, Seamlessly Integrating with Higher-Level Systems.

SECS / GEM

Supports SECS / GEM Protocol

Supports HSMS SECS/GEM Communication Protocols Used in the Semiconductor Industry, Ensuring Reliable Data Communication According to Specific Scenarios.

Hermes Standard

Supports Hermes Standard Communication Protocol Between SMT Equipment

Using the Hermes Standard Protocol, Data Communication Between SMT Equipment Is Possible Without Additional Devices or Extra Costs.

SMS & Email

SMS & Email Transmission

Automatically Sends SMS and Emails Stored in the Program Based on Field Conditions, Allowing Supervisors or Customers to Instantly Check the Factory Status.



Optimized Data Analysis

TDS Enables Efficient Data Retrieval and Table-Based Monitoring, Offering Intuitive Data Analysis Through Various Charts Such as Trend, Record, Bar, Meta, and Pie Graphs.

400+ Protocol

Full Support for 400+ Industrial Communication Protocols

Supports Various Industrial Communication Protocols for Stable Data Integration Between Equipment and Systems, Enabling Flexible Configuration and Operation Even in Complex Industrial Environments.

TOP Design Studio

TOP Design Studio Is Software for Creating and Editing HMI Project Files.
It Is Available for Free Download on the MX On Website (mxon.co.kr).

- **Intuitive UI** – Easy for Everyone
- **Legacy Model Migration** – ATOP / XTOP Compatible
- **Vivid Animations** – Smooth and Lifelike
- **Structured User Training** – Supported at Headquarters and Daegu Sales Office
- **YouTube Training Content** – Accessible Anytime, Anywhere
- **KakaoTalk Technical Support** – Instant Assistance On-Site

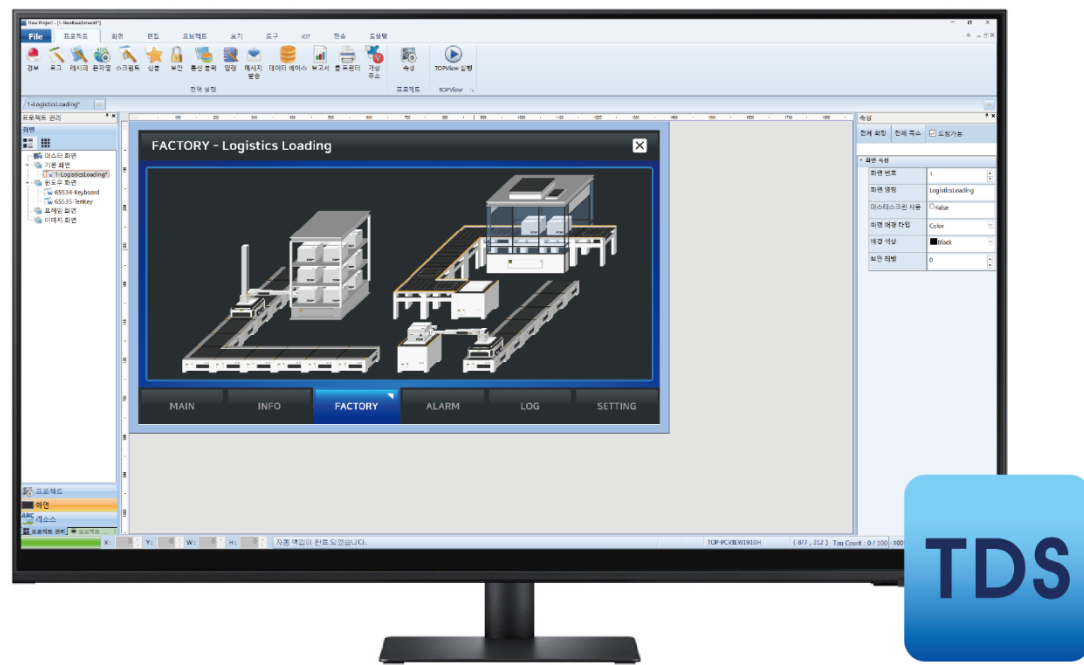

TOP Design Studio

KEY FEATURES



Function Implementation Integrated via [Effects & Actions]

Regardless of the Object's Shape or Type, Functions Can Be Implemented in a Consistent Manner Using the [Effects & Actions] Properties. Structured as [Condition] → [Effect] → [Action], the Specified Effect or Action Is Executed When the Condition Is Met.



Offline / Online Virtual Operation

Offline Virtual Operation:
Allows Direct Project Testing in TDS Without TOP or Controller.
Online Virtual Operation:
Enables Simultaneous Project Testing in TDS While Running the Actual Program on a PC-Connected Controller. (2-Hour Limit)



Continuously Updated Image Library

Offers a Variety of 16M Full-Color Images, Including Vector Images That Maintain Sharp Quality Regardless of Size, and 3D Libraries with Enhanced Depth Perception.



Optimized Data Analysis

TDS Enables Efficient Data Searching and Monitoring in Tabular Format, and Supports Intuitive Data Analysis Through Various Graphs Such as Trend, Record, Bar, Meter, and Pie Charts.

JavaScript

JavaScript Programming Support

Utilize the Widely Used JavaScript to Efficiently Extend Projects in TDS. From Simple Commands to Conditional Statements, Loops, and Functions, Various Programming Constructs Can Be Easily Implemented with Provided Samples.



Project Interoperability Between HMI and SCADA

TDS Supports Both TOP (HMI) and TOP-VIEW (SCADA) Projects, Allowing Seamless Conversion Between the Two.

TOP-VIEW SERIES

Industrial SCADA



TOP-VIEW LICENSE
(USB Key Lock)

TOP-VIEW

FEATURES



Database Linkage

Self-Database (SQLite) and Link-to External Database Is Available



HMI Compatibility

Same Communication Protocol Library as HMI Runtime Engine Sharing to Project Compatibility with HMI
HMI Data Saving to Database with DB Exchanger Function



Remote Monitor / Control

Monitoring and Control from Tablet PC or Mobile Devices by VNC
Web SCADA Function, Which Can Access from Web to Analyze and Control the Field
(* TOP-WVIEW License Is Needed)



Data Analysis and Report

Excel-Type Report Making Without Handwriting



Cloud Linked Frame Work

Supporting Global Network Protocols as OPC UA Linkage Functions with MES/ERP
Cloud Link by MQTT Function

TOP-VIEW LICENSE

No	Model	Tag Count
1	TOP-VIEW100P	100 Tags
2	TOP-VIEW300P	300 Tags
3	TOP-VIEW600P	600 Tags
4	TOP-VIEW1300P	1,300 Tags
5	TOP-VIEW2000P	2,000 Tags
7	TOP-VIEWFULLP	Full Tags
8	TOP-VIEW SINGLE	4,000 Tags

* TOP-VIEW SINGLE: Limits for Database, Report Interface, and Running Screen (1 Page)

TOP-WVIEW SERIES

Industrial Web SCADA

Chrome | Edge | Safari

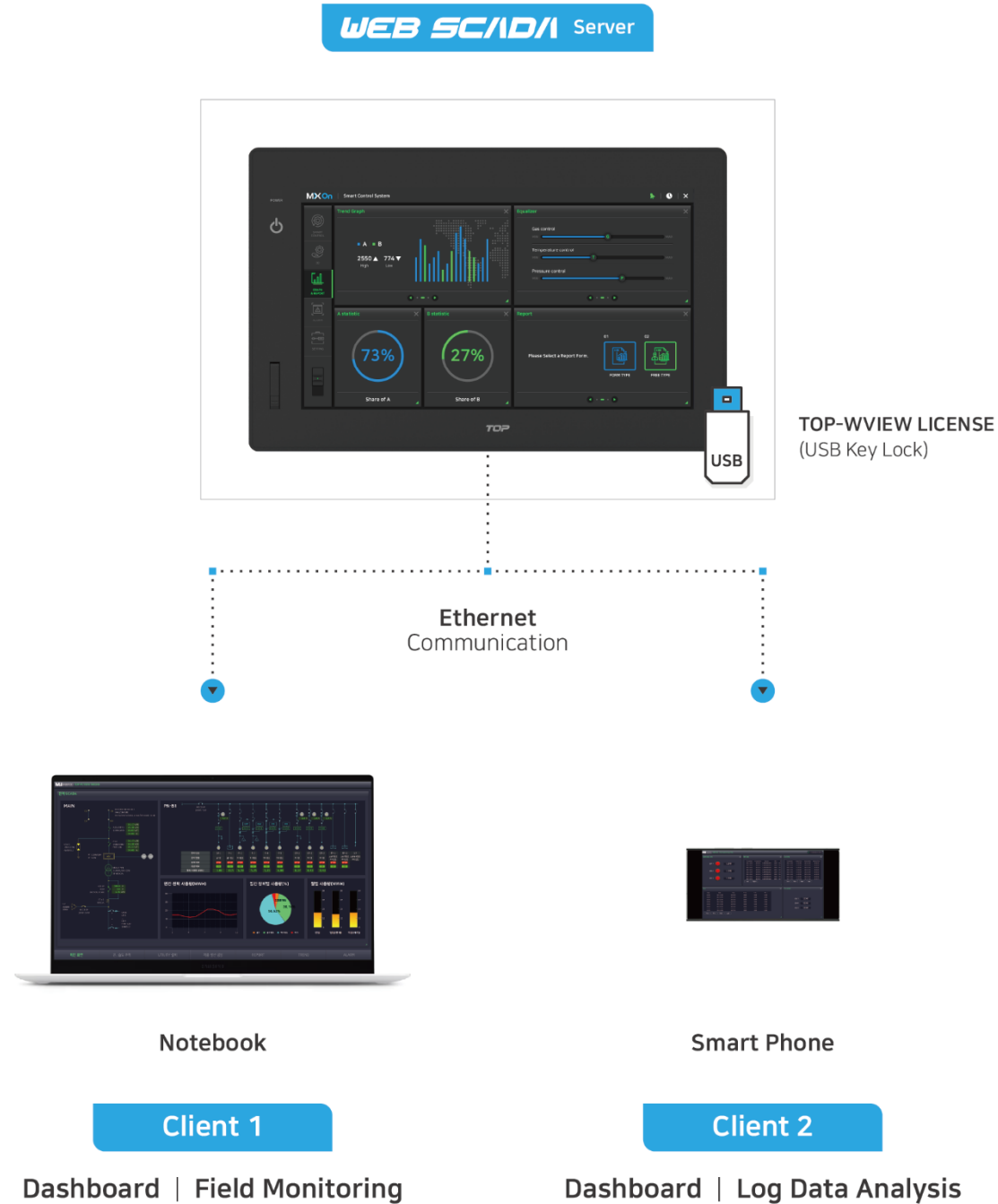

TOP-WVIEW

FEATURES



Individual Screen Monitoring

Free Access and Change of Screen Monitor and Data Analysis Regardless of Server's Running Screen (Different from VNC)



Multiple User Concurrent Connection

According to the License (USB Key Lock) Concurrent Connection of Users (2, 5, 10, Unlimited)



Responsive Design using Widgets

Dashboard Screen of Widgets Supported Flexible Re-Location According to the Screen Size of Device



HTML 5 and Web Standard

Maintain Compatibility Between Browsers Optimize Access to Web Pages



Use of Existing HMI Project

Simple Converting Between TOP (HMI) and Web SCADA Project

TOP-WVIEW LICENSE

No	Model	Concurrent Connection Users
1	TOP-WVIEW□□□□P_2U	2
2	TOP-WVIEW□□□□P_5U	5
3	TOP-WVIEW□□□□P_10U	10
4	TOP-WVIEW□□□□P_FU	Unlimited

TOP-WVIEW□□□□P_□□

- ① □□□□P (Tag Count): 300P / 600P / 1300P / 2000P / FULLP (Unlimited)
- ② □□ (Concurrent User Count): 2U / 5U / 10U / FU (Unlimited)

TOP-PCVIEW SERIES

Industrial Panel PC

INTERFACE

- SERIAL 4 PORTS
- ETHERNET 2 CHANNEL
- USB HOST 5 PORTS
- VGA(DP)
- HDMI OUT
- AUDIO



TOP-PCVIEW

FEATURES

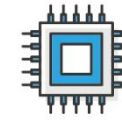

Intel® Core-i5 / i3 CPU

TOP-PCVIEW□□30□A: Intel® Core-i5 8365UE
 TOP-PCVIEW□□10□A: Intel® Core-i3 4010U



HMI / PC Compatibility

Mutual Compatibility Between TOP Project and SCADA Project
 Same Panel Cut as TOP Series



Large Capacity SSD

2.5 Inch SSD 256GB Default Supply

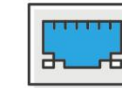

Ethernet 2 Channels

2 Independent Ethernet Network Channels



Excellent Fanless Structure

Highly Efficient Heat Sink Installed
 Fit to Quiet Location, No Need for Fan Maintenance



USB 5 Ports

USB 3.0 – 2 Ports, USB 2.0 – 3 Ports
 USB 3.1 – 4 Ports, USB 2.0 – 1 Port for 1930HA Model



Aluminum Frame

Strong Durability and Refined Design of Aluminum Body



Front IP65 Compatible

Safe Use in Wet and Dusty Environment



5-wired Touch Panel

5-Wired Analog Touch Panel (19 Inch)

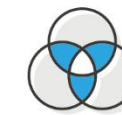

16M Full Color

Bright and Clean Full Color, Vector Image Library

TOP-PCVIEW SPECIFICATIONS

Functional	1				2		
	TOP-PCVIEW 1930HA	TOP-PCVIEW 1530XA	TOP-PCVIEW 1910HA	TOP-PCVIEW 1710SA	TOP-PCVIEW 1510XA	TOP-PCVIEW 1210XA	TOP-PCVIEW 1010XA
System	Processor Number	Intel® Core-i5 8365UE			Intel® Core-i3 4010U		
	CPU Speed	1.6GHz@4.1GHz(4C/8T)			1.7GHz(2C/4T)		
	Memory	DDR4 SO-DIMM 8GB			DDR3L SO-DIMM 8GB		
	Storage	2.5" SSD 256GB					
	OS	1 Windows 11 IoT Enterprise LTSC 2024 2 WES7 KOR 32/64, ENG 32/64(Selectable), Windows 10 IoT 1809 LTSC 64bit KOR/ENG(Selectable)					
Display	System Utility	WinClon(Recovery system)			Acronis true image(Recovery system)		
	Display Type	18.5" TFT Color	15" TFT Color	18.5" TFT Color	17" TFT Color	15" TFT Color	12.1" TFT Color
	Color	16M Colors					
	Display Area(mm)	409.8 x 230.4	304.1 x 228.1	409.8 x 230.4	337.92 x 270.34	304.1 x 228.1	245.76 x 184.32
	Resolution(dot)	1366 x 768	1024 x 768	1366 x 768	1280 x 1024	1024 x 768	
Touch	Brightness Level	5 Levels(Selected Windows)			5 Levels(Selected BIOS)		
	Backlight Type	LED					
	Backlight Life	50,000 hours					
	Touch Type	Analog resistive film					
	Touch Life	1 million times or more					
Serial COM1, COM2	1 RS-232C, RS-422/485 Asynchronous(Selected BIOS), Data bit: 7/8 bits, Stop bit: 1/2 bits, Parity bit: None/Odd/Even Baud rate: 2400~115.2kbps, Connector: DSUB 9pin x 1, 3.5mm 5P x 1 2 RS-232C Asynchronous, Data bit: 7/8 bits, Stop bit: 1/2 bits, Parity bit: None/Odd/Even Baud rate: 2400~115.2kbps, Connector: DSUB 9pin x 2						
	Serial COM3, COM4	1 RS-232C Asynchronous, Data bit: 7/8 bits, Stop bit: 1/2 bits, Parity bit: None/Odd/Even Baud rate: 2400~115.2kbps, Connector: DSUB 9pin x 2 2 RS-232C, RS-422/485 Asynchronous(Selected BIOS), Data bit: 7/8 bits, Stop bit: 1/2 bits, Parity bit: None/Odd/Even Baud rate: 2400~115.2kbps, Connector: DSUB 9pin x 1, 3.5mm 5P x 1					
Ethernet	1 IEEE 802.3, IEEE 802.3u, IEEE 802.3z, IEEE 802.ab, 10BaseT/100BaseT/1000BaseT, Connector: RJ-45 x 2 2 IEEE802.3/IEEE802.3u/IEEE802.3ab, 10BaseT/100BaseT/1000BaseT, Connector: RJ-45 x 2						
	USB Host	1 USB 2.0 Compatible, Output 5Vdc/0.5A, Connector: USB Type Micro B x 1 USB 3.1 Compatible, Output 5Vdc/0.9A, Connector: USB Type A x 4 2 USB 2.0 Compatible, Output 5Vdc/0.5A, Connector: USB Type A x 2, USB Type Micro B x 1 USB 3.0 Compatible, Output 5Vdc/0.9A, Connector: USB Type A x 2					
Front Power Button	Electrostatic touch						
VGA	1920 x 1200 at 60Hz						
HDMI Out	1 HDMI v1.4, HDMI output, Max. Resolution: 4096 x 2160 at 24Hz, Connector: HDMI x 1 2 HDMI v1.4a, HDMI Output, Max. Resolution: 4096 x 2304 at 24Hz, Connector: HDMI x 1						
DP Out	1 DP v1.2, HDMI output, Max. Resolution: 4096 x 2306@60Hz, Connector: DP x 1						
Audio	High definition audio(HD), Line-in, Line-out, Mic-in						
Power	Input Voltage	220Vac(100 ~ 240Vac) 50/60Hz					
	Power Consumption	60W				50W	
	Voltage Sag	100Vac, Within 10ms					
	Insulation Resistance	500Vdc, 10MΩ					
	Operation Temperature(°C)	0 ~ +60(No humidity)					
Environment	Storage Temperature(°C)	-20 ~ +60					
	Operation Humidity(%RH)	0 ~ 95(No dew)					
	Atmosphere	No corrosive gas					
	Vibration Endurance	Amplitude: 10sF<25Hz(2G), X, Y, Z each direction(for 30 minutes)					
	Noise Immunity	1000Vp-p(Pulse width 1μs)					
	Static Electricity Discharge	Connective discharge from EN61000-4-2: ±4kV					
	Shock Endurance	10G X, Y, Z each direction(for 3 times)					
	Ground Connection	Class 3(100Ω under)					
	Protection Classification	Front side: IP65, Rear side: IP2X					
	Withstand Voltage	500V(Line-Line)					
Structure	Certification	KC, CE					
	Panel Cut(mm)	479 x 298	355 x 286	479 x 298	400 x 334	355 x 286	306 x 247
	External Dimension(mm)	497 x 316 x 94.8	370 x 301 x 87	497 x 316 x 86.6	414 x 348 x 86.6	370 x 301 x 87	320 x 261 x 93.5
	Weight(kg)	5.6	5.0	5.5	5.2	5.0	3.0
	Cooling System	Natural air circulation					
	Case Material	Metal					

INTERFACE

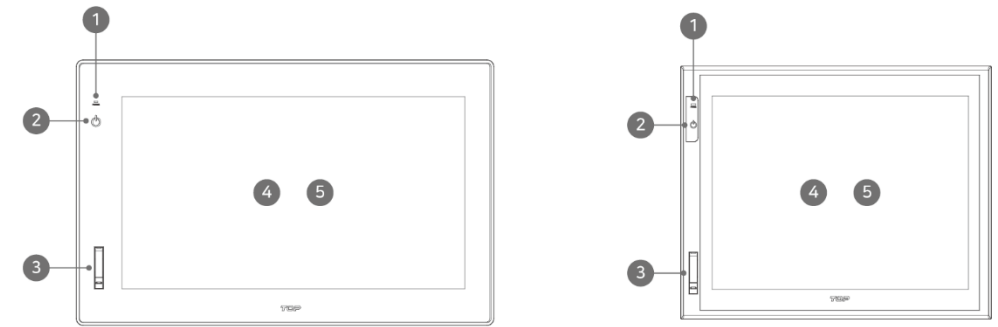

No	Name	Description
1	Power LED	System Power Status
2	Power Switch	System Power ON/OFF, Capacitive Switch (* ON/OFF by touching 3 seconds)
3	Front USB Port	Front USB HOST Port
4	TFT LCD	TFT 16M Color LCD
5	Touch Panel	Analog Resistance Touch

TOP-PCVIEW□□30□A

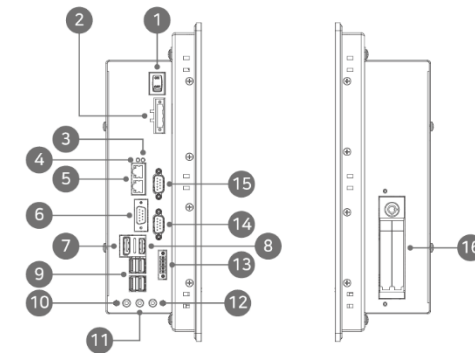

No	Name	TOP-PCVIEW□□30□A
1	Power Switch	Rocker Switch-2P
2	Power Terminal	Terminal Block-3P
3	Disk LED	LED
4	전원 LED	LED
5	LAN Port #1, #2	RJ-45 2Ch
6	COM1	DSUB-9(Male)
7	DP	DP Port
8	HDMI	HDMI Port
9	USB	USB 4Ch
10	SPK	Audio Jack(3.5Pi)
11	LINE-IN	Audio Jack(3.5Pi)
12	MIC	Audio Jack(3.5Pi)
13	COM2	Terminal Block-5P
14	COM3	DSUB-9(Male)
15	COM4	DSUB-9(Male)
16	HDD Rack	2.5" bay Slot

TOP-PCVIEW□□10□A

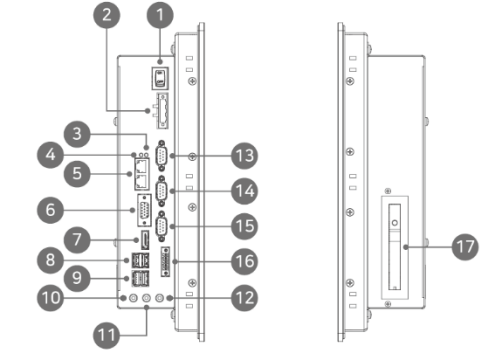

No	Name	TOP-PCVIEW□□10□A
1	Power Switch	Rocker Switch-2P
2	Power Terminal	Terminal Block-3P
3	Disk LED	LED
4	Power LED	LED
5	LAN Port #1, #2	RJ-45 2Ch
6	VGA	DSUB-15P
7	HDMI	HDMI Port
8	USB #1	USB 2Ch
9	USB #2	USB 2Ch
10	SPK	Audio Jack(3.5Pi)
11	LINE-IN	Audio Jack(3.5Pi)
12	MIC	Audio Jack(3.5Pi)
13	COM1	DSUB-9(Male)
14	COM2	DSUB-9(Male)
15	COM3	DSUB-9(Male)
16	COM4	Terminal Block-5P
17	HDD Rack	2.5" bay Slot

DRAWING

TOP-PCVIEW1930HA

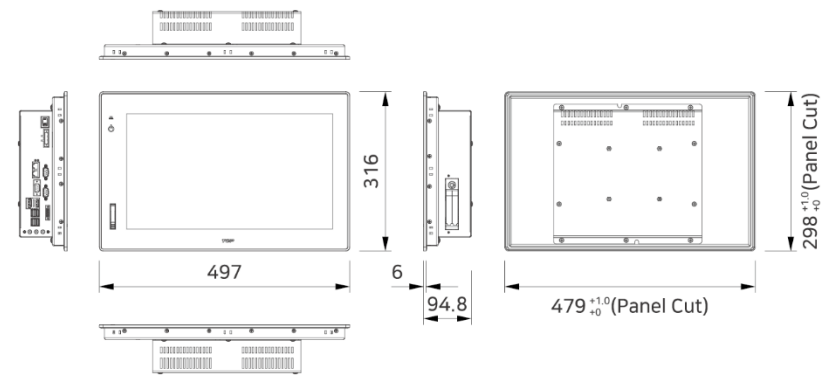

TOP-PCVIEW1530XA

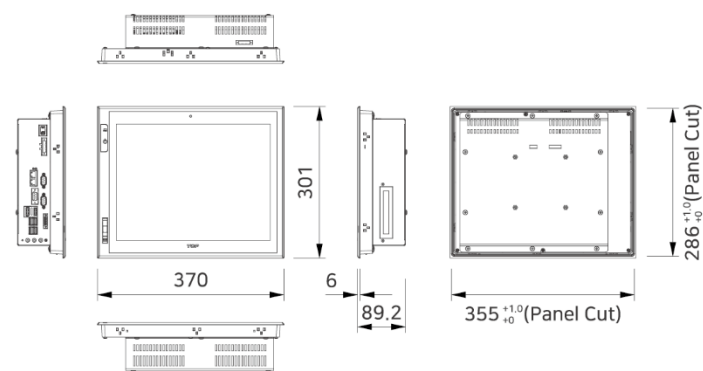

TOP-PCVIEW1910HA

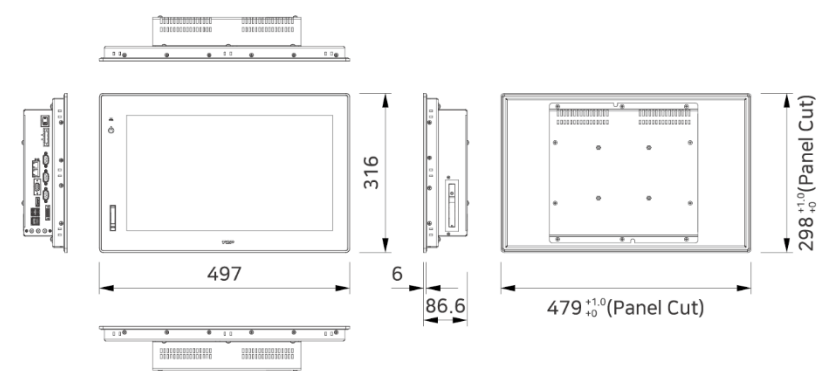

TOP-PCVIEW1710SA

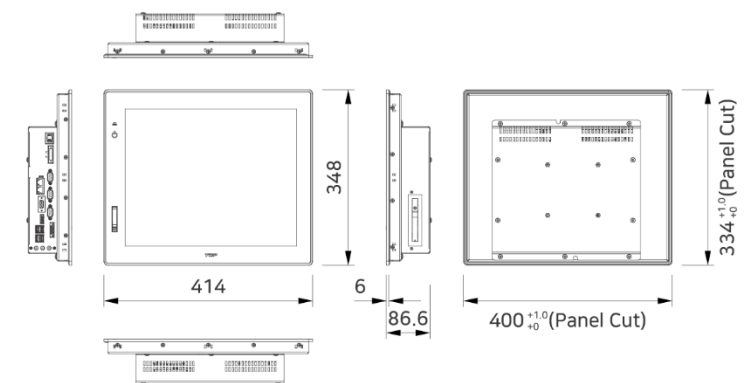

TOP-PCVIEW1510XA

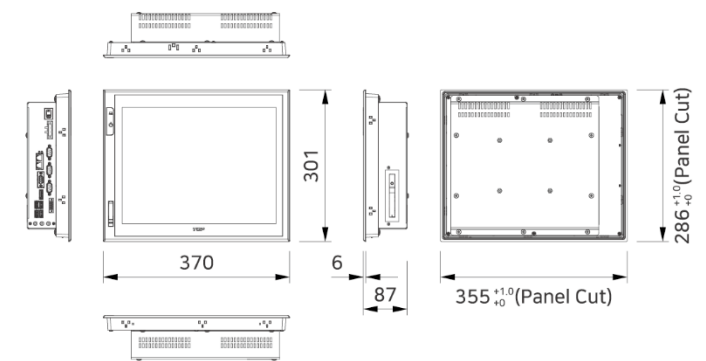

TOP-PCVIEW1210XA

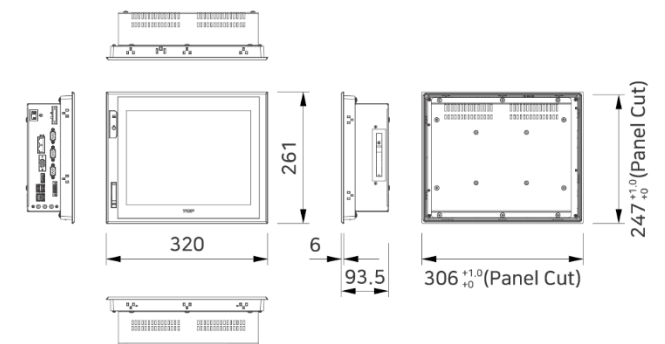

TOP-PCVIEW1010XA

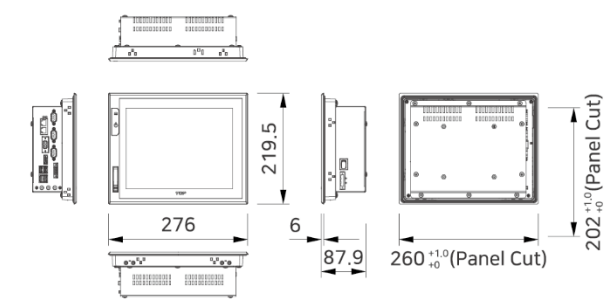

MPC SERIES

Industrial Box PC

INTERFACE *Varies By Model.

- SERIAL 4 PORTS ▪ ETHERNET 2 CHANNEL ▪ USB HOST 4 PORTS
- DISPLAY PORT OUT ▪ HDMI OUT ▪ AUDIO OUT

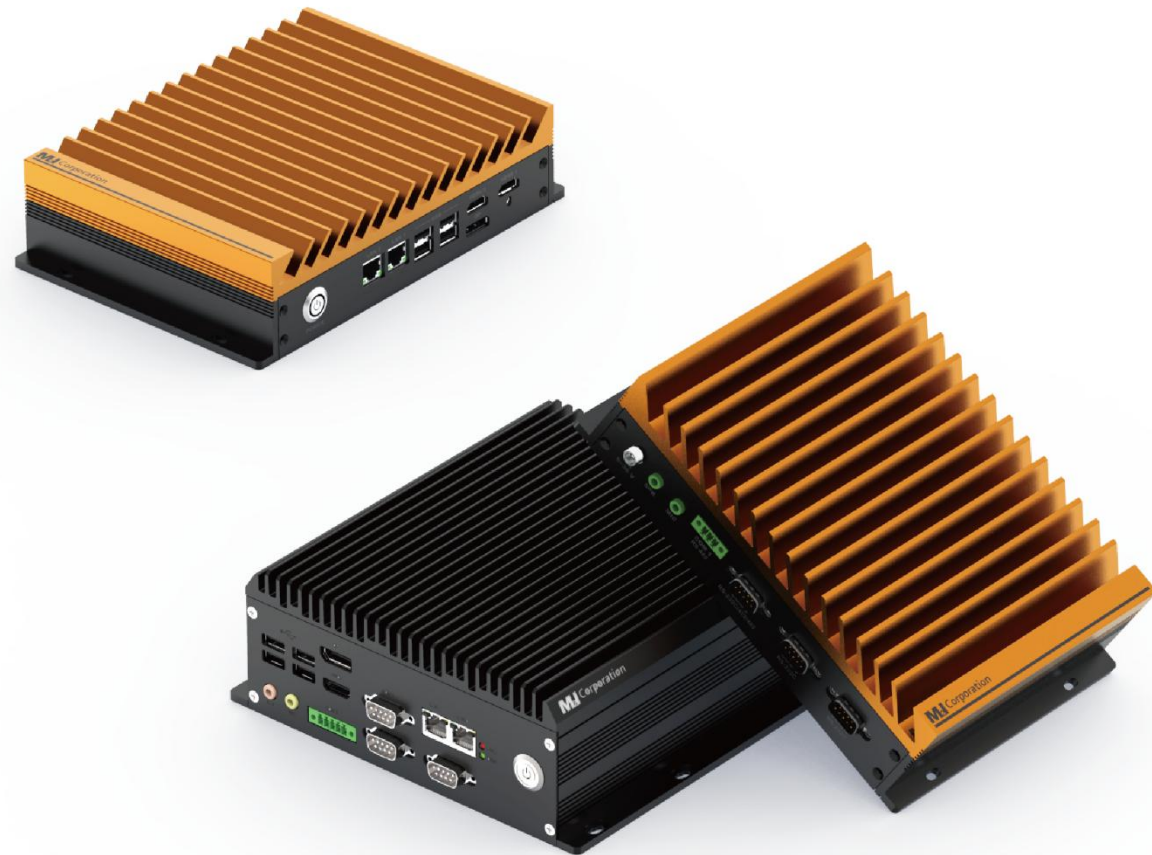

FEATURES

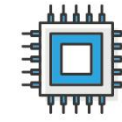

Fanless Intel 8th Core-i5 CPU

High-Performance Implementation with a Fanless 4-Core / 8-Thread Design



Optimized Heat Dissipation Design

Efficiently Designed for CPU Cooling to Ensure Stable Performance Without Degradation



Supports Simultaneous 4K HDMI and DP Display Output

Convenient Connection to Various Monitors via HDMI and DP

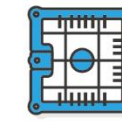

Supports Mounting Holes for MDP Monitors

Easily Attach MDP Monitors Using the Mounting Holes

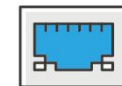

Provides 2 Ethernet Channels

Supports Heterogeneous Networks with Different IPs



Provides 4 Serial Ports

Supports RS-232C and RS-422/485 Communication



Provides 4 USB HOST Ports

Ports Available for Connecting Mouse, Keyboard, USB Memory, Barcode Scanner, etc.

MPC SPECIFICATIONS

Functional	MPC-B1500A	MPC-B1500D	
Main System	CPU Processor and Speed	Intel® 8th Core-i5 8365UE: 1.6GHz@4.1GHz(4C/8T)	
	Memory	DDR4 S0-DIMM 8GB	
	Storage	2.5" SSD 256GB	
	OS and Recovery Software	Windows 10 IoT LTSC 1809, Winclon 6.0 premium	
Interface	Serial COM1	RS-232C, RS-422/485 Asynchronous(Selected BIOS) Data bit: 7/8 bits, Stop bit: 1/2 bits, Parity bit: None/Odd/Even Baud rate: 2400~115.2kbps Connector: DSUB 9pin	
	Serial COM2	RS-232C, RS-422/485 Asynchronous(Selected BIOS) Data bit: 7/8 bits, Stop bit: 1/2 bits, Parity bit: None/Odd/Even Baud rate: 2400~115.2kbps Connector: 3.5mm 5P	
	Serial COM3	RS-232C Asynchronous Data bit: 7/8 bits, Stop bit: 1/2 bits, Parity bit: None/Odd/Even Baud rate: 2400~115.2kbps Connector: DSUB 9pin	
	Serial COM4	RS-232C Asynchronous Data bit: 7/8 bits, Stop bit: 1/2 bits, Parity bit: None/Odd/Even Baud rate: 2400~115.2kbps Connector: DSUB 9pin	
etc.	Ethernet	10BaseT/100BaseT/1000BaseT Connector: RJ-45 x 2	
	USB Host	USB 3.1 Compatible, Output 5Vdc/0.9A Connector: USB Type A x 4	
	Display Port(DP) OUT	Max. 4096 x 2360@60Hz	
	HDMI OUT	Max. 4096 x 2160@30/24Hz	
	Audio	High definition audio(HD), 3.5mm, SPK-out, Mic-in	
	Power Button	LED Push button	
	Status indicator LED	Power and disk status	
	Input Voltage	Embedded SMPS type, 110Vac/220Vac, 7.62mm 3P TB	Adaptor type, Output 12Vdc ~ 24Vdc supports, DC Jack
	Power Consumption	Max. 100W(*CPU Turbo boost full load) Typ. 40W	
	Voltage Sag	220Vac, Within 10ms	12Vdc, Within 10ms
	Insulation Resistance	500V DC, 10MΩ	500V DC, 10MΩ
	Operation Temperature(°C)	0 ~ +60	
	Storage Temperature(°C)	-40 ~ +60	
	Operation Humidity(%RH)	0 ~ 90(No dew)	
	Atmosphere	No corrosive gas	
Vibration Endurance	Amplitude: 10≤F<25Hz(2G) X,Y,Z each direction(for 30 minutes)		
Noise Immunity	1000Vp-p(Pulse width 1μs)		
Electrostatic Discharge	Connective discharge from EN61000-4-2: ±4kV		
Shock Endurance	10G X,Y,Z each direction(for 3 times)		
Ground Connection	Class 3(100Ω or under)	-	
Protection Classification	IP2X		
Certification	KC, CE		
Structure	External Dimension(mm)	206 x 66 x 202	206 x 66 x 121
	Weight(kg)	3	2
	Cooling System	Natural air circulation	
	Case Material	Metal	

DRAWING

MPC-B1500A

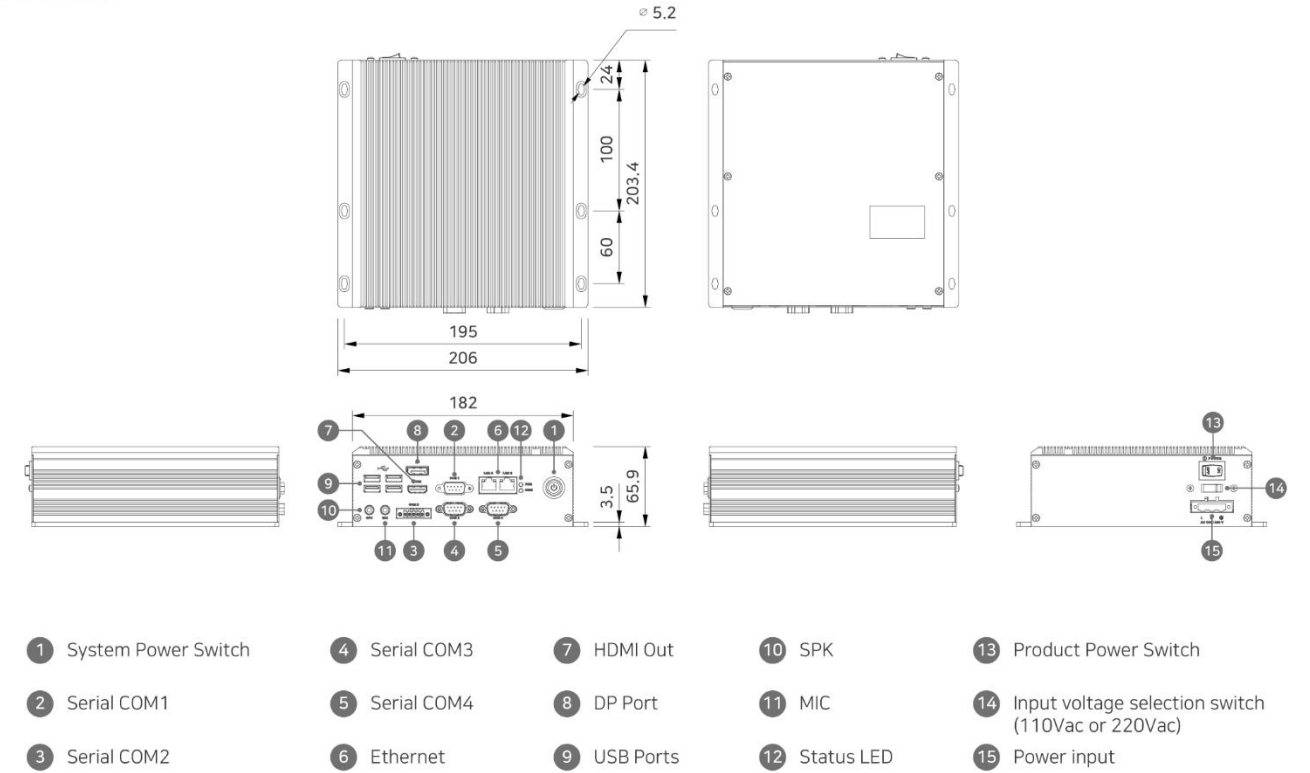

MPC-B1500D

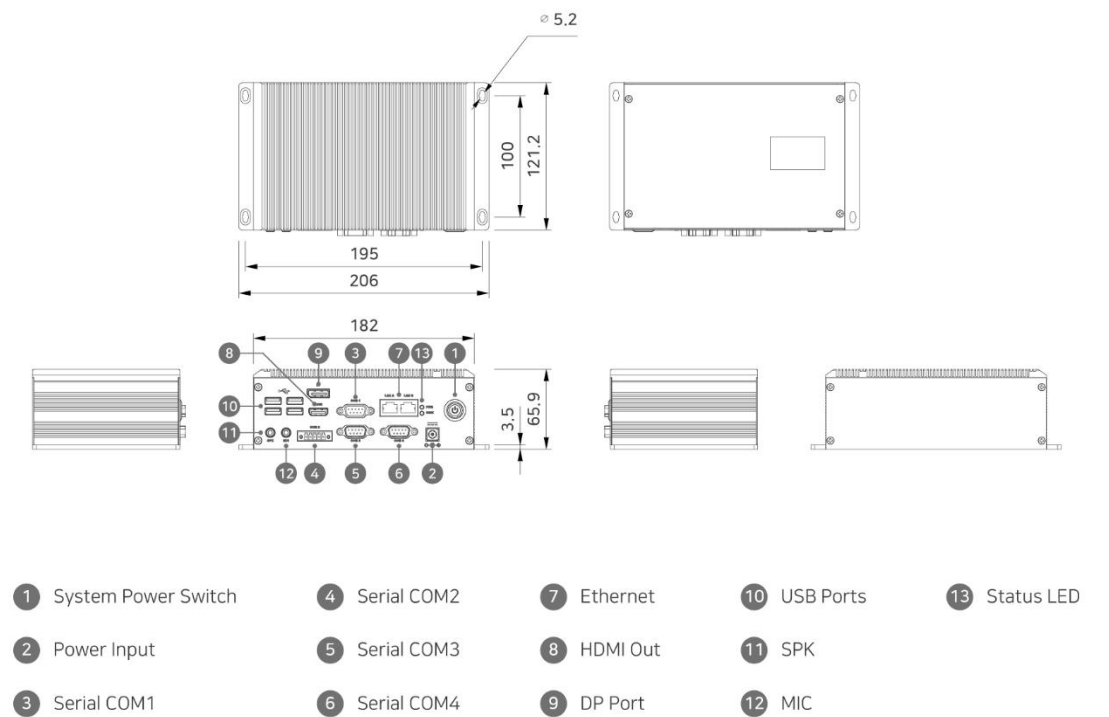

MPC SPECIFICATIONS

Functional	MPC-B1510D	MPC-B1310D	MPC-B1010D	
Main System	CPU Processor and Speed (Base@Max), (Core/Tread)	Intel® Core™ i5-1245UE Processor Base: Pcore 1.6, Ecore 1.2 Max: Pcore 4.40, Ecore 3.30	Intel® Core™ i3-1215UE Processor Base: Pcore 1.2, Ecore 0.9 Max: Pcore 4.40, Ecore 3.30	intel® Processor N97, 6M Cache, up to 3.60 GHz Base 2.0GHz, Max 3.6GHz
Memory	DDR5 SO-DIMM 16GB			
Storage	M.2 nvme 256G		M.2 Sata 256G	
OS and Recovery Software	Windows 10 IoT Enterprise LTSC 2021, Windows 11 IoT Enterprise LTSC 2024			
Serial COM1, COM2	#COM1 RS-422/485 Asynchronous only #COM2 RS-232C,RS-422/485 Asynchronous(Selected BIOS) Data bit: 7/8 bits, Stop bit: 1/2 bits, Parity bit: None/Odd/Even Baud rate: 2400~115.2kbps Connector: COM1 3.5mm 3P x 1, COM2 DSUB 9pin x 1			
Interface	Serial COM3, COM4 RS-232C Asynchronous Data bit: 7/8 bits, Stop bit: 1/2 bits, Parity bit: None/Odd/Even Baud rate: 2400~115.2kbps Connector: DSUB 9pin x 2			
Ethernet	IEEE 802.3i/802.3u/802.3ab/802.3bz, 10BASE-T/100BASE-TX/1000BASE-T/2.5GBASE-T Connector: RJ-45 x 2	IEEE 802.3i/802.3u/802.3ab, 10BASE-T/100BASE-TX/1000BASE-T Connector: RJ-45 x 2		
USB Host	USB 3.2 gen 2(10G) x 4			
Front Power Button	LED Push Button			
HDMI Out	HDMI 2.0, up to 4096 x 2160 @ 60 Hz x 2		HDMI 2.0, up to 4096 x 2160 @ 60 Hz x 1	
DP Out	DP1.2, up to 4096 x 2304 @ 60 Hz x 1			
Audio	High Definition Audio(HD), Line-out, Mic-in			
Power	Input Voltage DC Jack Adaptor(9Vdc ~ 36Vdc)			
Power Consumption	50W			
Voltage Sag	19Vdc, Within 10ms			
Insulation Resistance	500Vdc, 10MΩ			
Operation Temperature(°C)	0 ~ +60(No humidity)			
Storage Temperature(°C)	-40 ~ +60			
Operation Humidity(%RH)	0 ~ 95(No dew)			
Atmosphere	No corrosive gas			
Vibration Endurance	Amplitude: 10sF < 25Hz(2G), X,Y,Z each direction(for 30 minutes)			
Environment	Noise Immunity 1000Vp-p(Pulse width 1μs)			
Electrostatic Discharge	Connective discharge from EN61000-4-2: ±4kV			
Shock Endurance	10G X,Y,Z each direction(for 3 times)			
Ground Connection	Class 3(100Ω under)			
Protection Classification	IP2X			
Certification	KC, CE			
Structure	Panel Cut(mm)	-	-	
External Dimension(mm)	228 x 55 x 160			
Weight(kg)	-			
Cooling System	Natural air circulation			
Case Material	Metal			

DRAWING

MPC-B1510D
MPC-B1310D

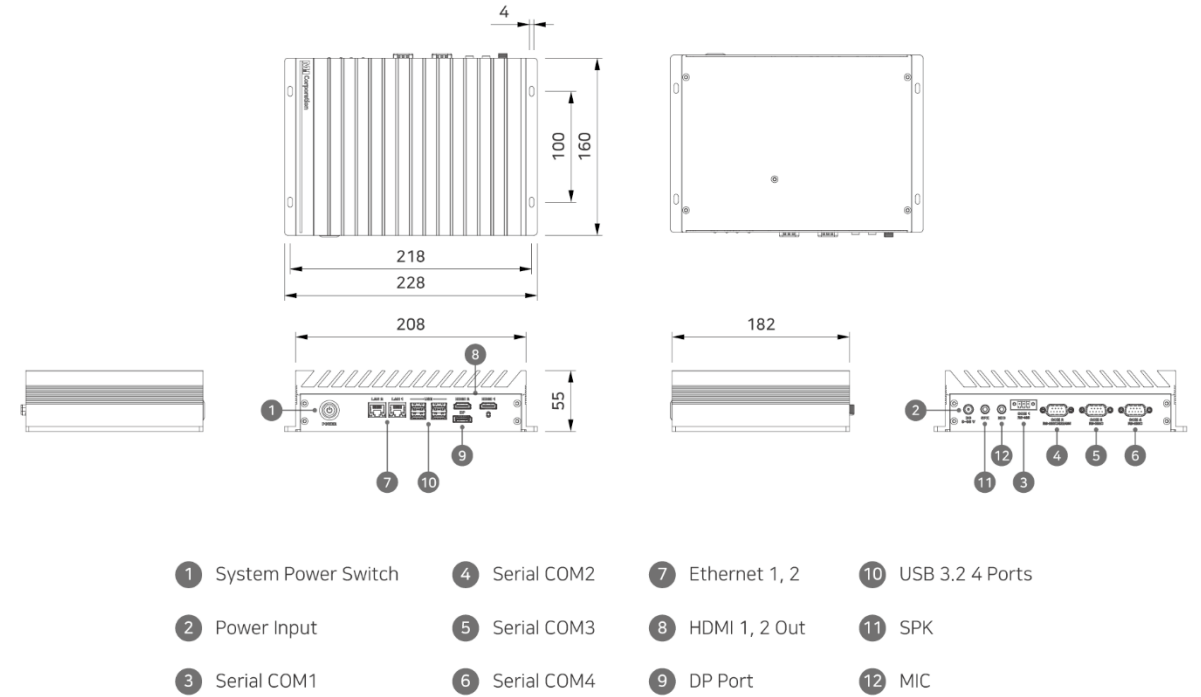

MPC-B1010D

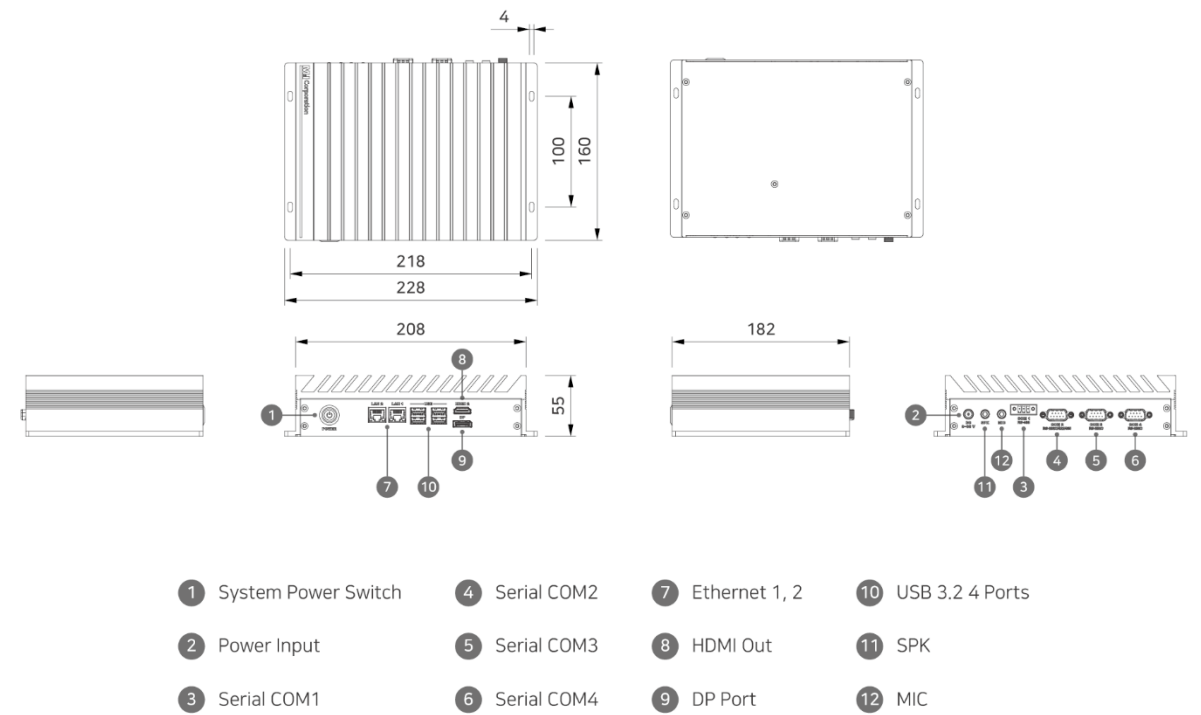

MDP SERIES

Industrial Touch Monitor

INTERFACE *Varies By Model.

- HDMI
- USB
- DP



FEATURES

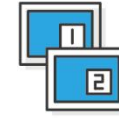

2 Channels / 1 Channel Model Selective

Display Change by Switching Button



Explosion-Proof Structure

The First Monitor with Explosion-Proof Structure



Capacitive Touch

Clear Display with Capacitive Touch
IK7-Grade Tempered Glass



FHD LCD

16:9, 19 Inch, FHD LCD (1920 x 1080)



Front USB Port

Connection Ports to Connect Mouse, Keyboard,
USB Memory, Barcode Reader



Aluminum Frame

Strong Durability and Refined Design of Aluminum
Body



HDMI / USB / DP

2 Channels (HDMI - 2 Ports, USB - 5 Ports)
1 Channel (HDMI - 1 Port, DP - 1 Port, USB - 2 Ports)

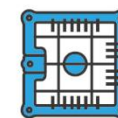

VESA Hall on Rear Side

Convenient Attachment with M2I's Box HMI and Box
PC

MDP SPECIFICATIONS

Functional	MDP-DC1900WD	MDP-SC1900WD
Display Type	18.5" TFT Color	
Color	16M Colors	
Aspect Ratio	16:9	
Display Area(mm)	409.8 x 230.4	408.96 x 230.04
Recommend Resolution	1920 x 1080	
Viewing Angle(H/V)	89/89/89/89	85/85/85/85
Contrast Ratio	1000 : 1	1200 : 1
Response Time	20ms	30ms
Brightness	350Cd/m ²	
Backlight Type	LED	
Backlight Life	50,000 hours	
Touch Type	Capacitive Touch	
HDMI Input	2 Ports	1 Port
DP Input	-	1 Port
USB Up Stream	2 Ports	1 Port
USB Down Stream	2 Ports	-
USB Host	1 Port	
Capacitive Touch Button	KVM/Up/Down/Menu, Select/Power	-
Button(Tact Switch)	-	Up/Down/Menu, Select/Power
Input Voltage	24Vdc(20~28Vdc)	
Power Consumption	40W	
Voltage Sag	24Vdc, Within 10ms	
Insulation Resistance	500Vdc, 10MΩ	
Operation Temperature(°C)	-10 ~ +50	
Storage Temperature(°C)	-20 ~ +60	
Operation Humidity(%RH)	0 ~ 90(No dew)	
Atmosphere	No corrosive gas	
Vibration Endurance	Amplitude: 10sF < 25Hz(2G) X,Y,Z each direction(for 30 minutes)	
Noise Immunity	1000Vp-p(Pulse width 1μs)	
Electrostatic Discharge	Connective discharge from EN61000-4-2: ±4kV	
Shock Endurance	10G X,Y,Z each direction(for 3 times)	
Ground Connection	Class 3(100Ω under)	
Protection Classification	IP65(Front)	
Certification	CE, KC, UL/cUL	
External Dimension(mm)	477.4 x 328.4 x 63.5	477.4 x 328.4 x 71.4
Panel Cut(mm)	463 x 314	
Weight(kg)	5.0	4.7
VESA Wall Mount Holes(mm)	100 x 100	
Cooling System	Natural air circulation	
Case Material	Aluminum + Plastic	

DRAWING

MDP-DC1900WD

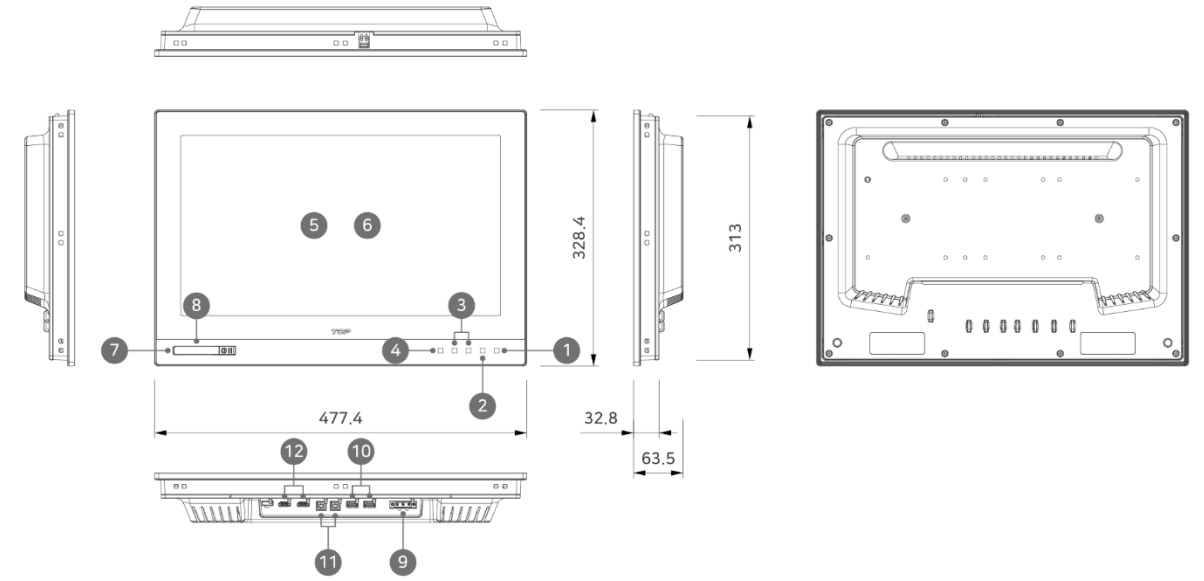

- ① Power LED & Button ④ Display Change Button ⑦ USB Cover ⑩ USB Downstream Port 1, 2
- ② OSD MENU Button ⑤ LCD Panel ⑧ USB Downstream Port 3 ⑪ USB Upstream Port 1, 2
- ③ Up/Down Button ⑥ Touch Panel ⑨ Power Input ⑫ HDMI Input 1, 2

MDP-SC1900WD

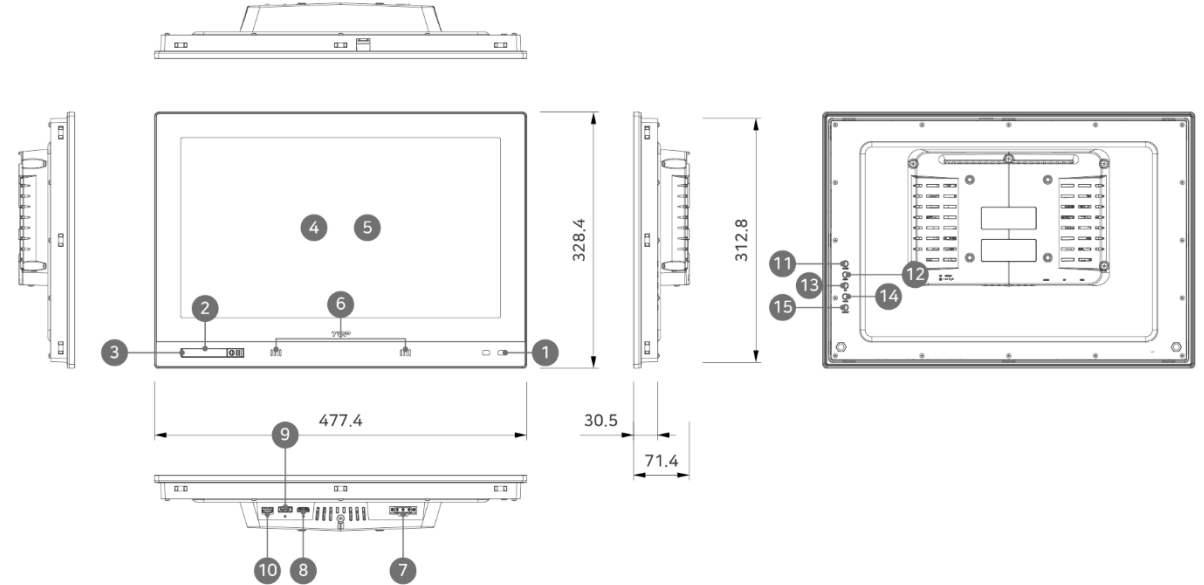

- ① Status LED ④ LCD Panel ⑦ Power Input ⑩ USB Type A ⑬ Up Button
- ② USB Host ⑤ Touch Panel ⑧ HDMI Input ⑪ Power Button ⑭ Down Button
- ③ USB Cover ⑥ Speaker ⑨ DP Port ⑫ Menu Button ⑮ Select Button

GLOBAL BUSINESS NETWORK



More than 20 Overseas Partners

China, the United States, Vietnam, Japan, South Africa, Turkiye, Singapore, Russia, Greece, France, Jordan, Honduras, Nigeria, Indonesia, India, Israel, Iran, Thailand, Malaysia, and more.

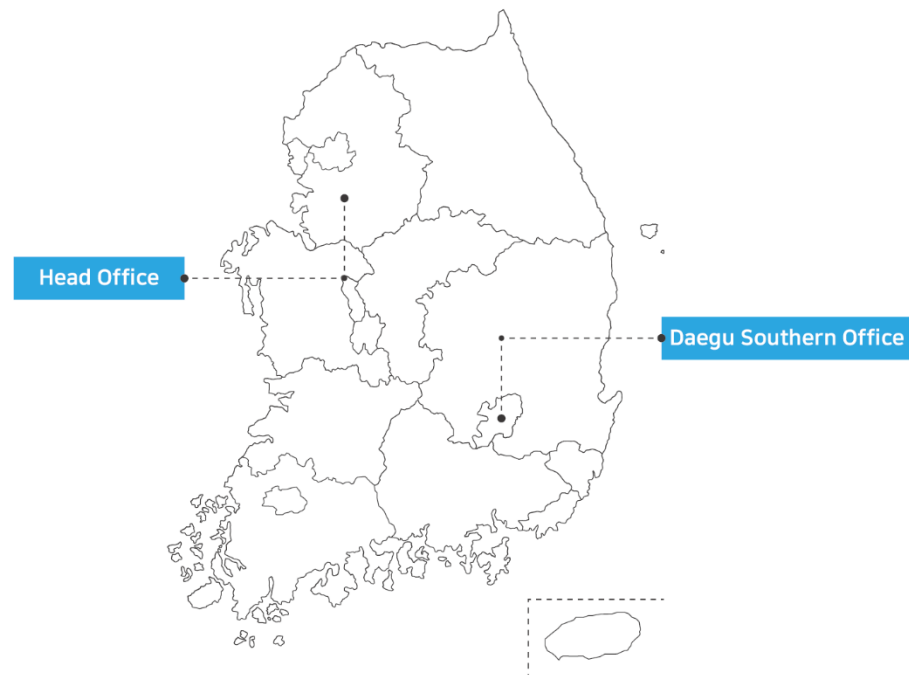

More than 40 Domestic Partners

Seoul, Gyeonggi, Daejeon, Daegu, Gwangju, Ulsan, Changwon, Busan, and more.

MX On Official YouTube Channel

Access a Wide Range of Educational Content and the Latest Updates from MX On, Faster Than Anywhere Else



KakaoTalk Technical Support

Quickly and Efficiently Resolve Technical Issues by Sending Real-Time Photos and Videos, Even in Noisy Industrial Environments



On-Site Inspection Service (B/S, Field Visit)

From Checking Aging Products to Consulting for New Replacements, Experience It All Directly at Your Site Now



Commitment to Our Customers

Dialogue with Customers – Putting Customers First and Creating Value Together
 Sustainable Growth – Achieving Reliability and Productivity Through Continuous R&D
 Embracing New Changes – A Total Smart Factory Solution Platform Company Based on AX·DX